



Inside this issue:

- 1 Monthly Updates
- 2 Event News
- 3 Kornit Breeze Update
- 4 Support Updates
- 5 Special Announcements



**Save up to
€26,000
Kornit Show Special
@ FESPA 2010**

[CLICK HERE](#)



**kornit Breeze 921
Innovation Seminar**

Monthly Updates

Kornit to Exhibit Leading Direct-On-Garment Technologies at FESPA 2010

We are happy to announce that Kornit will be exhibiting our advanced technologies at Fespa 2010, Europe's biggest trade show of screen and digital printing technologies!

The show will be held from June 22 to June 26, 2010 at the Messe München International Exhibition Center, Germany.



Hall A2-Stand 240

For this year's Fespa event, Kornit will take the main lead in the show's textile & fabric arena as the **"Fespa Fabric Platinum Sponsor"**.

During the show, Kornit will display our various Direct-On-Garment technology solutions, including our complete product line of high-speed, industrial digital D.O.G printers. Among the exhibits to be presented at our booth (Hall A2-stand 240) will be the newly developed Kornit Breeze 921 entry-level Direct-On-Garment printer, introduced to Europe for the first time. In addition, the company will showcase the **Kornit Storm 931-8** and **Kornit Thunder 932-6** high-speed digital printers, as well as the **Kornit Paradigm 933** digital add-on station for screen printing carousels which will be exhibited with Heinz Walz GmbH, Kornit's distributor for Germany (Hall A2-stand 328).

[Read More...](#)

Join our session at the Fespa Fabric Innovation Theater!

In addition to exhibiting our complete line of products on the exhibition floor, Kornit will also be taking part in the Fabric Innovation Theater conducted by Fespa throughout the conference. Kornit's session will focus on the company's recent technological innovations, highlighted by the new **Kornit Breeze 921** entry-level printer. The session will be presented by our own Director of Product Marketing and Business Development at Kornit, Mr. Yuval Neria, and will be held on June 22nd, 2:00 pm in Hall A1, at the Messe München Exhibition Center.



[Read more...](#)

Event News

An Open House Celebration at Kornit North America!

Kornit North America is pleased to invite you to our Open House Celebration to be held during May and June, 2010 at the new Kornit Digital North America Inc. offices.

Meet our distributors!

SPS-I Open House | May 18-May 20, 2010

Richmond Graphic Open House | June 2-June 4, 2010

Hirsch International Open House | June 7-June 12, 2010

Exhibited Printers

- The newly developed **Kornit Breeze 921** entry-level Direct-On-Garment printer for new entrants and small businesses
- **Kornit Thunder 932-6** single-pallet Direct-On-Garment printer for medium-level production businesses
- **Kornit Storm 931-8** dual-pallet Direct-On-Garment printer for high-level production businesses

During the Open House period, you'll be able to spend time with art specialists, as well as with Kornit certified technicians, while running in a production type environment. You are more than welcome to bring your garments and your files with you, and we will make sure you will get what you came for and more...

Register here!

Email Miriam Sanchez at: miriams@kornit.co.il or call 888.4kornit.

We look forward to see you at KDNA!

More Upcoming Events

Texpo Eurasia | May 15-May 18, 2010, Istanbul, Turkey

27th Textile, Woven, Yarn, Finishing, Knitting, Hosiery Machines, Side Industries and Chemical Fair, Texpo Eurasia 2010 will be the biggest trade fair promoting all kinds of products from the Textile Industry. Kornit will exhibit the **Kornit Paradigm 933** digital add-on station for screen printing carousels.

Come to see us with Ber Tekstil, our local distributor for Turkey!

[Read More...](#)

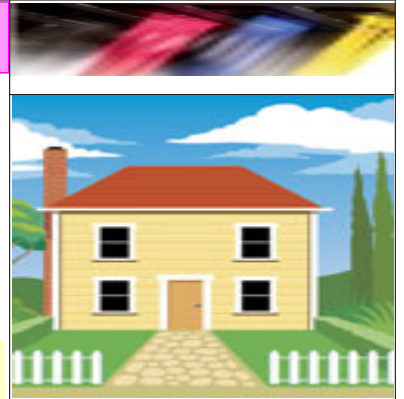

Kornit **Breeze 921**



Kornit **Storm 931-8**



Kornit **Thunder 932-6**

Texpo Eurasia 2010

27th Textile, Woven, Yarn, Finishing, Knitting, Hosiery Machines, Side Industries And Chemicals Fair



Kornit Breeze 921 Update

Breeze 921 Sales Opening Coming Soon...

Kornit Breeze 921 is designed from the ground up to meet the quality and performance requirements of professional garment decorators at an entry level price and low cost of operation.

One of the main advantages of the Breeze is its integrated PreT™ Solution for garment pretreatment. Why is this such a great benefit? Because pretreatment is usually a costly process that requires dedicated equipment, space and manpower, and that creates a complicated and time consuming workflow. Breeze customers enjoy faster production and a smooth workflow combined with capital and operational savings as additional pretreatment machines and heat presses no longer need to be purchased, and also only one operator is required to handle the entire production process.

The Kornit Breeze 921 is being beta tested by selected Kornit customers and is planned to be released for sale by the end of Q2 2010 through Kornit's worldwide distribution network (click here for our list of distributors). Ink consumption evaluations are being conducted as part of the Beta program and will be included in an ROI model that will become available when the product is released for sale.

We would like to welcome you to take a first hand look of the Breeze 921 that will be demonstrated in action at our FESPA 2010 exhibit, Hall A2-Booth 240. Our technical and marketing teams will be there to guide you and answer all of your questions.

Pricing Information (US\$) *

Printer	55,000 \$US	
Printer Stand	400 \$US	Optional
QuickP for Breeze	1,300 \$US	Software license
Installation & Training	1,500 \$US	Price applicable for US installation sites only
Shipping		Per location
Ink	180 \$US/ Liter	CMYK & white inks
First year warranty	Free of charge	Multiple post-warranty support programs available

Book your Kornit Breeze 921

If you are considering adding the new Kornit Breeze 921 to your business, please don't forget to submit an "Application of Interest" and join our waiting list!

[Online Application of Interest](#)

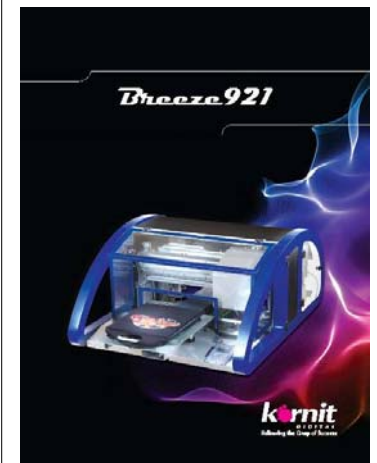

[Download Brochure](#)



* * * * *

For Kornit Breeze international pricing please contact your local distributor

For more information about the Breeze 921
[Click here](#)

Support Updates

New Products Available!

Spray Wiping Upgrade Kit

The Kornit Spray Wiping Upgrade Kit for automatic handling of unique garment pretreatment is now available for all Kornit Storm 931 models including Inca machines.

The new Spray Wiping System automatically wipes the garment surface after the preT solution is applied. The wiping system evenly spreads the preT solution over the entire printing surface thereby enhancing print quality on dark garments that are less absorbent to fluid.

Place your order at: order@kornit.co.il.

Drip Protection Band for Pallets

The Drip Protection Band is a rubber strap fastened to the printer pallet, designed to prevent droplets of fixation solution from dripping onto the garment when unloading after the printing process is complete. The protection band is available for all Kornit printers and models, so don't hesitate to make your production even easier than it is!

Place your order at: order@kornit.co.il.

Maintenance System Gas Spring

Going on vacation? There is an easier way to shut off the machine for a long period without wasting time or money!

If you need to close your business for longer time periods than just the weekends, you no longer need to flush the heads or extra-maintenance them in any way. In order to prevent the heads from clogging or drying-out., the Maintenance System Gas Spring works its magic and does it all for you without having you spend a dime, by stably fixing the maintenance tray in a capping position while the machine and the air compressor are shut off. With the Maintenance System Gas Spring, all you have to do is just shut off your equipment and you are good to go!

Place your order at: order@kornit.co.il.

May Maintenance Tip!

Garment printing is known for its lint-saturated environment, where lint is likely to penetrate the machine's encoder strip area. This may cause misalignment of the image position or sporadic data printing on the garment. In order to properly protect the encoder, it is recommended to clean the encoder readers with a lint-free towel once a month.



Many customers already purchased their Kornit Printer Yearly Maintenance Kit, How about you?

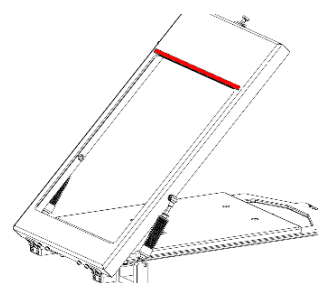

Drip Protection Band for Pallets

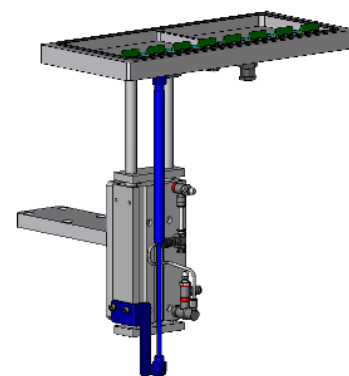

Maintenance System Gas Spring



Special Announcements

Kornit Appoints New ICS Personnel in Asia Pacific!

Kornit is pleased to announce the appointment of Mr. Marcel Kaiser as Kornit Digital Asia Pacific Customer Support Technical Specialist..

Marcel has 10 years of experience in the digital printing industry. In his previous rolls, Marcel worked as a Customer Support Manager for Scitex Vision & Objet Geometries, both companies that specialize in digital printing technologies.

Marcel will be in charge of all customer support activities for the Asia Pacific region as a part of Kornit's ICS Division, and will provide second line support to all Kornit's Asia Pacific distributors and their service teams. As a part of our strategic goal to improve customer satisfaction in the Asia Pacific region, Marcel will lead the ICS operation in this territory and will work to provide fast, direct and top professional support to our clients.

We are also pleased to announce that Mr. Bill Lake will be joining Marcel as the new Kornit Digital Asia Pacific Office Administrator.

In his previous roll, Bill worked as an Office Administrator Manager for Objet Geometries. Bill will be in charge of all logistics, orders & CRM activities in the Asia Pacific region, and will provide logistical support to the distributors.

Our new Asia Pacific members will be based in the Kornit Digital Asia Pacific office (KDAP) in Hong Kong, to be opened in May 2010. An official announcement will be issued by Kornit with the opening of the KDAP operation.

You can contact our KDAP staff at the following email addresses:

Marcel Kaiser: marcelk@kornitics.com

Bill Lake: Billl@kornit.co.il

Please join us in congratulating Marcel with his new position at Kornit!



Mr. Marcel Kaiser, ICS
Technical Specialist for
Asia Pacific



Kornit International Customer Support

Kornit Breeze 921
Small printer. **Big difference.**

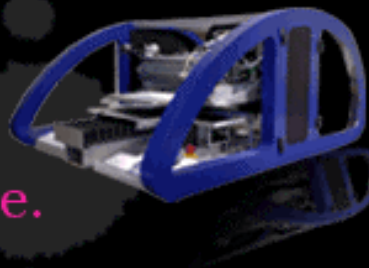

kornit
DIGITAL
Following the Drop of Success

Kornit Digital Ltd.

12 Ha'Amal St., POB 11781, Afek-Park, Rosh-Ha'Ayin 48092, Israel
Tel:+972.3.908.5800 Fax:+972.3.908.0280

Kornit Digital North America Inc.

9077 N Deerbrook Trail, Brown Deer WI 53223, USA. Toll Free: 888-456-7648
Tel: 414-354-0905 Fax: 414-354-0906

www.kornit-digital.com | kornit@kornit.co.il